

Step 1

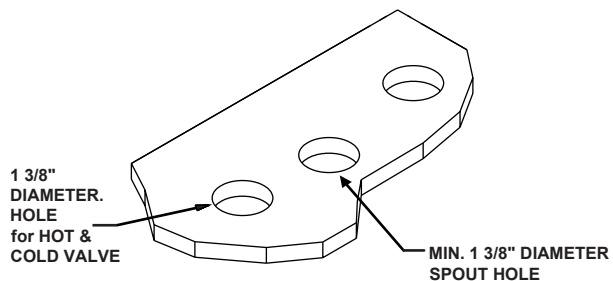

Should a counter top need to be drilled, please reference the diagram above.

Step 2

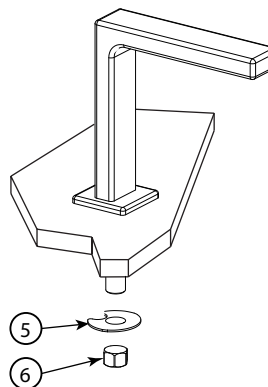

Insert spout base nipple into center hole in lavatory or counter top. Install stainless washer (5) nut (6) on spout nipple and tighten

Step 3

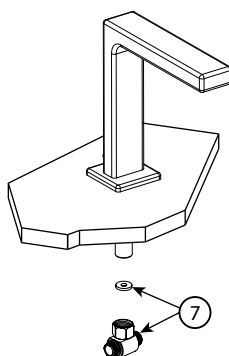

Install spout tee assembly (7) as shown in diagram.

Step 4

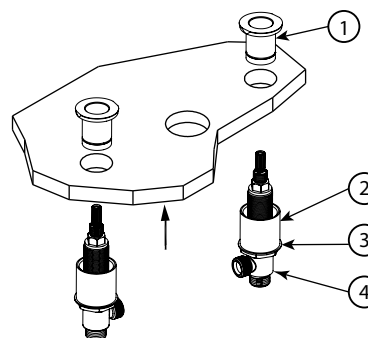

Remove top fastening nut and washer (1) from the lavatory valve. (NOTE A: All lever handle sets are supplied with one right-hand valve and one left-hand valve. Install valve with blue dot on the cold side [Round handle sets are supplied with two hot valves that turn in the same direction]). Insert valve from below through hole in lavatory or countertop.

Step 5

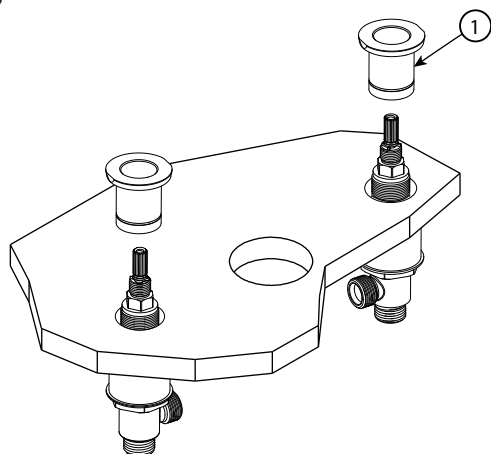

Reattach top fastening nut and washers (1).

Step 6

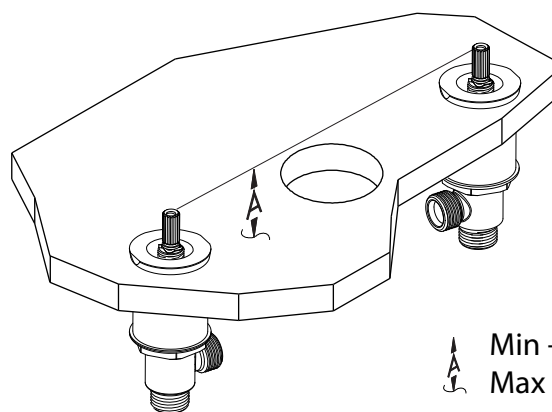

Min - 1"
Max - 1 1/2"

Set valve to proper rough-in height "A", by adjusting bottom fastening nut. Secure valve by tightening top fastening nut. Repeat procedure for the second lavatory valve.

Step 7

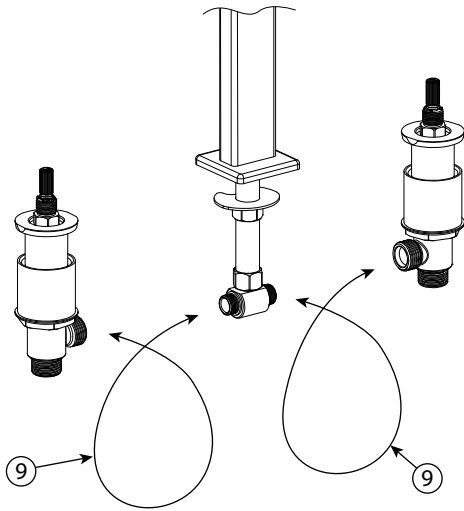

Connect stainless steel flex lines (9) from valve outlets to spout tee (7). Flex lines should be looped as shown in diagram. FLEX LINES MUST NOT BE KINKED. Adjust valves and or spout teeto eliminate any kinking in the flex lines. Install escutcheons onto the valves and hand tighten. DO NOT OVER-TIGHTEN. Install handles onto valve stems.

STEP 8 - DRAIN ASSEMBLY

Insert ***Pre-assembled drain rim (A)** into the basin placing the **Teflon washer (B)** under the rim. From below slip on **washer (C)** onto the bottom thread of the drain rim and secure to basin with **drain nut and washer (D & E)** then insert **Tail tube drain (F)** onto the **drain rim (A)**

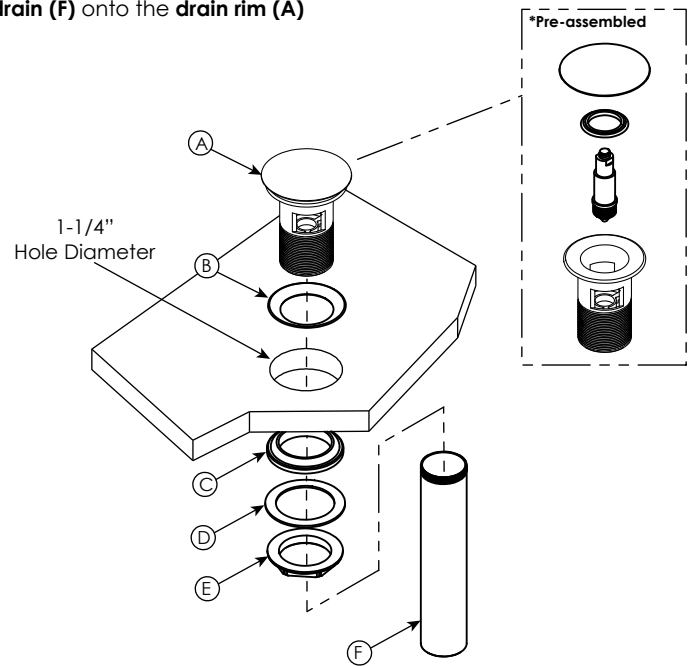

Step 9

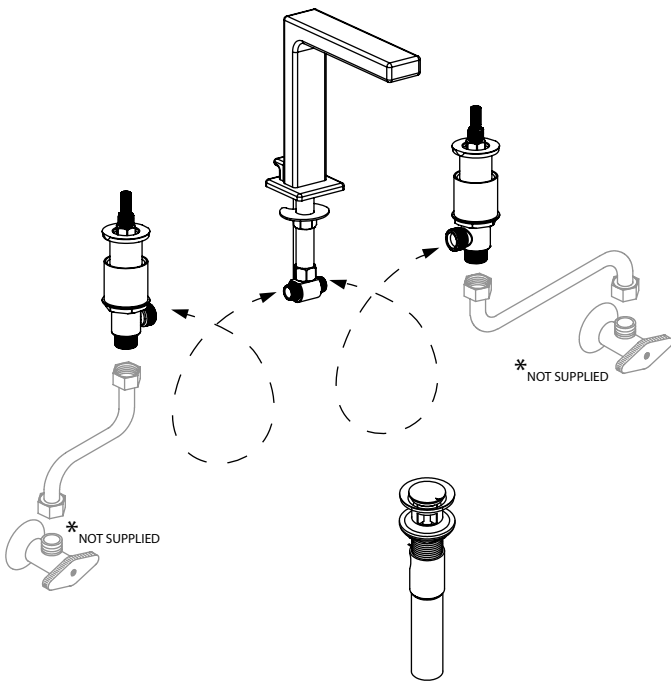

THIS STEP MUST BE COMPLETED TO ADHERE TO THE LIMITED LIFETIME WARRANTY.

Flush hot and cold supply lines before connecting faucet to supply lines. Connect the supplies to the bottom of the lavatory valves using the brass coupling nuts provided or with a flexible line. Connect your waste P-trap to the drain tail piece.

* SUPPLY LINES AND ANGLE STOPS NOT INCLUDED

Step 10 - Handles Assembly

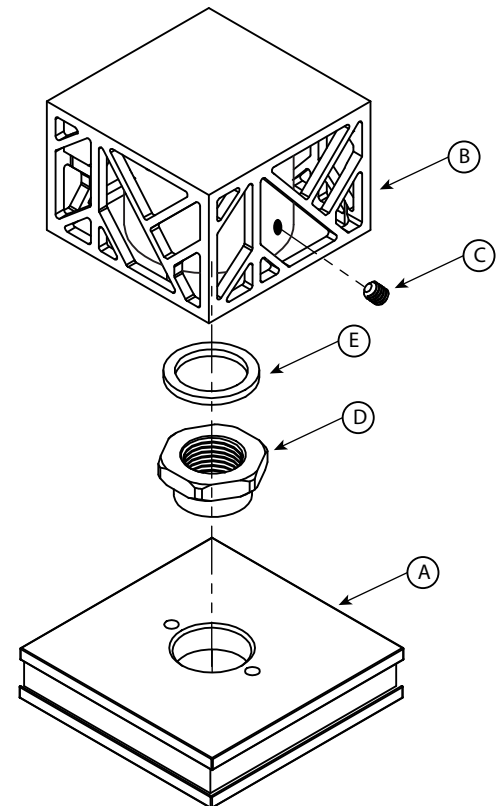

Place the pre-assembled base (A) over flush mount. Align base and secure using centering nut (D). Connect the pre-assembled cage handle (B) on to broach then tighten set screw (C) for final assembly.

Note: Ensure Washer (E) is properly inserted underneath the handle hub to avoid cage handle from damaging the base.

Limited Warranty

PHYLIRICH®

This Limited Warranty is expressly in lieu of any other warranties, expressed or implied, arising by law or otherwise, including without limitation, any implied warranty of merchantability or fitness for a particular purpose. This Limited Warranty may not be altered, varied, or extended, except by a written instrument executed by Phylrich. The remedy or repair or replacement as provided under this Limited Warranty is exclusive. In no event shall the manufacturer be liable for any consequential or incidental damages to any person, whether or not occasioned by negligence of Phylrich, including without limitation damages for loss of use, costs of property damage or other monetary loss.

Some states do not allow the exclusion or limitation of incidental or consequential damages or limitations on how long an implied warranty lasts, so the above limitations or exclusions may not apply. This warranty gives you specific legal rights and you may also have other rights which vary from state to state.

This warranty covers product installed in the United States and Canada.

Several types of limited warranties are applicable to decorative plumbing and hardware products as follows:

Mechanical Warranty: This warranty covers the ability of the product to function properly under normal conditions. Our products are warranted to the original purchaser to be free of defects in material and workmanship for a period of 10 years from the date of purchase.

Because plumbing valves have several mechanical differences due to the function i.e. faucet valves vs. thermostatic shower valves, the following valve warranties are established:

Ceramic disc valves are warranted for life as long as the original purchaser owns the house in which they are installed.

Other types of valves, to include thermostatic and balance pressure shower valves, etc. are warranted for one year from the date of purchase.

Finish Warranty: Because certain metal finishes are more durable than others and certain applications require more durability, 4 finish warranties have been established:

- Certain metal finishes such as antique brass, satin nickel and satin brass are coated with an organic clear coating. These coated types of finishes are warranted for 10 years from the date of shipment to the original purchaser.
- Finishes with harder surfaces such as polished chrome, Physical Vapor Deposition (PVD) finishes and powder coated finishes are warranted for as long as the original purchaser owns the home.
- The so called "living finishes" are not warranted. These finishes have no protective coating and thus are designed to change with age and use.
- Finishes on Drains: Because of the use and abuse of the metal surface that occurs on sink and bath drains with soaps and cleaning solutions, only drains in the "B" category above are warranted. This warranty is for one year from date of purchase. Drains in the above A and C categories are not warranted.

The warranties described above are specific rights, but there may be other rights which vary from state to state.

If you have a problem with one of our products, here is what is covered and how you should proceed:

First of all, consult the dealer from whom you purchased the product. Please provide proof of purchase in the form of an original invoice or receipt. If the dealer is an authorized Phylrich dealer, he will review the problem and contact the Phylrich customer service department on your behalf. If you cannot contact your dealer, please e-mail our customer service at customer.service@phylrich.com and describe the problem along with your contact information.

The Phylrich Warranty does not assume liability for charges such as labor, freight, removal and reinstallation or injuries resulting from a defective product. Phylrich will repair or replace defective parts after it has been established that the product is defective and that the parts are covered by this warranty. Phylrich reserves the right to determine whether to repair or replace the product under consideration.

Phylrich products must be installed in accordance with the instructions provided with the product. Make sure your installer flushes out all debris such as solder before final assembly. Plumber's putty should not be used on any decorative surface as it could harm the finish and void the warranty.

For proper maintenance do not use any abrasive cleaners, strong cleaning solutions or polishing compounds. Usually a soft damp cloth will suffice. Non-abrasive waxes can also be used.